

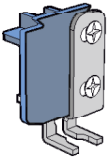

PANTA REI AUTO

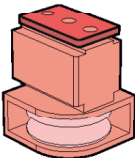

PRA01

DISPOSITIVO DI RICHIUSURA BREVETTATO/PATENTED SELF CLOSING DEVICE

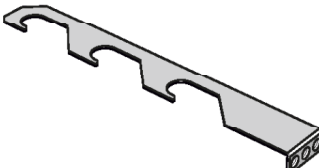
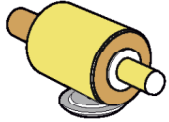
| | | | | |
|---|--|---|---|--|
| <p>STAFFA / BRACKET</p>  <p>01</p> | <p>PULEGGIA / PULLEY</p>  <p>02</p> | <p>CAVO ELASTICO ELASTIC ROPE</p>  <p>03</p> | <p>AGGANCIIO / GRIP HOOK</p>  <p>04</p> | <p>AMMORTIZZATORE DAMPER</p>  <p>05</p> |
|---|--|---|---|--|

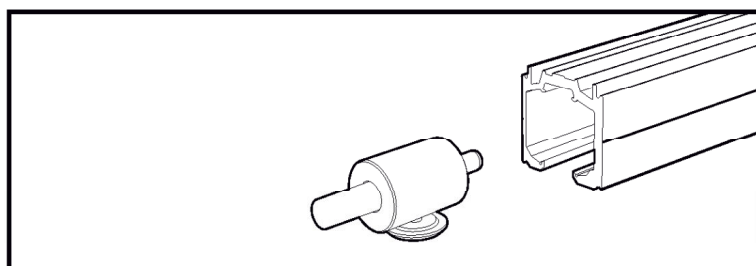
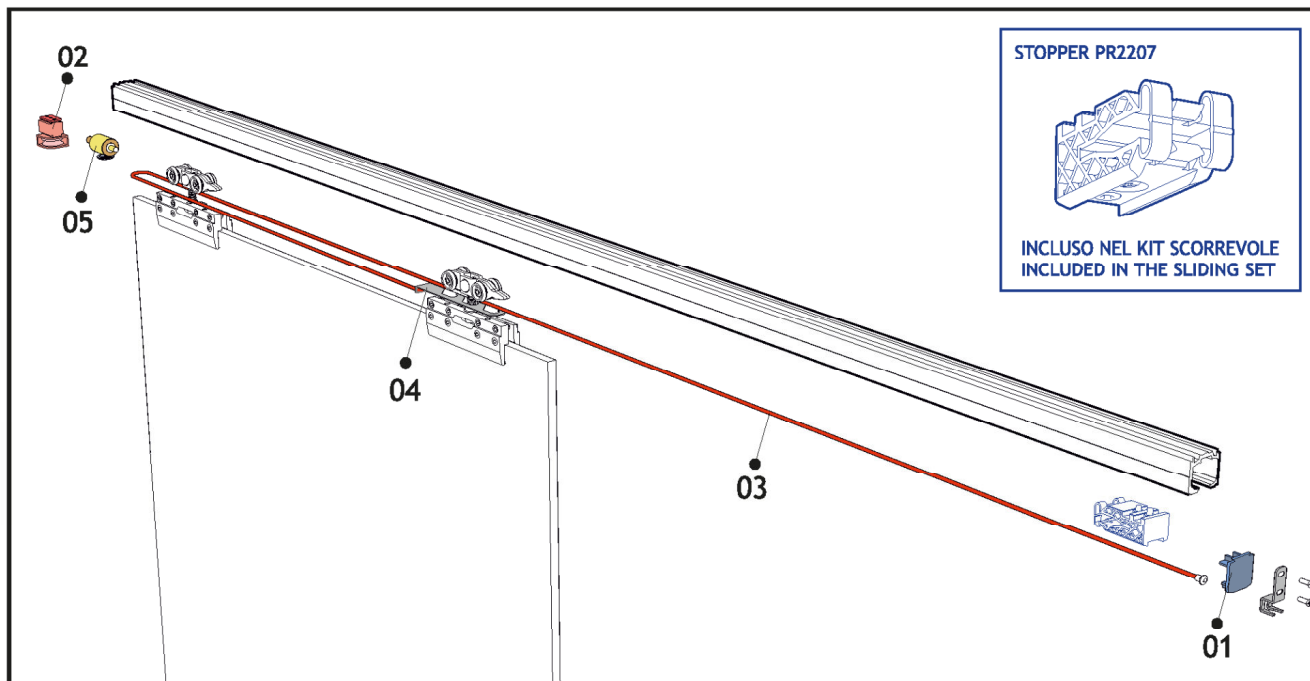

Dispositivo di chiusura automatica dell'anta completo di ammortizzatore di fine corsa per PANTA REI
Si abbina ai seguenti kit carrelli senza soft close: PR02-60, PR02-110, PR03-60, PR03-80, PR05-60, PR05-110, PR07-60 e PR07-100

ATTENZIONE: l'uso del dispositivo richiusore necessita differente posizionamento delle pinze e inferiore altezza della porta rispetto ai kit standard, da farsi in base alle indicazioni alle pagine successive

Self closing device with travel limit damper for PANTA REI
It matches with the following no soft close carriage sets: PR02-60, PR02-110, PR03-60, PR03-80, PR05-60, PR05-110, PR07-60 e PR07-100

PLEASE NOTE: self-close device requires different clamp positioning and lower height of the door compared to standard sets. Please look at the following pages

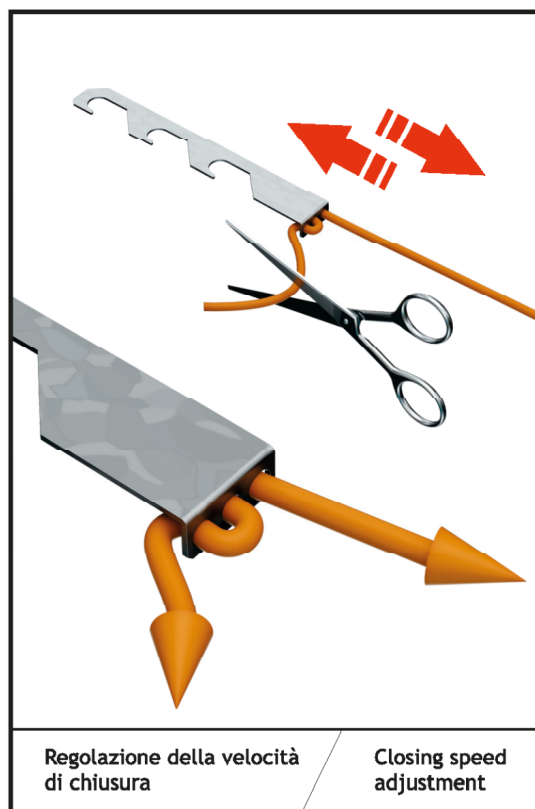

| | |
|-----------------------------------|---------------------------------|
| <p>MAX</p> <p>← →</p> <p>1500</p> | <p>MAX</p> <p>KG</p> <p>110</p> |
|-----------------------------------|---------------------------------|

PRA02

DISPOSITIVO DI RICHIUSURA BREVETTATO/PATENTED SELF CLOSING DEVICE

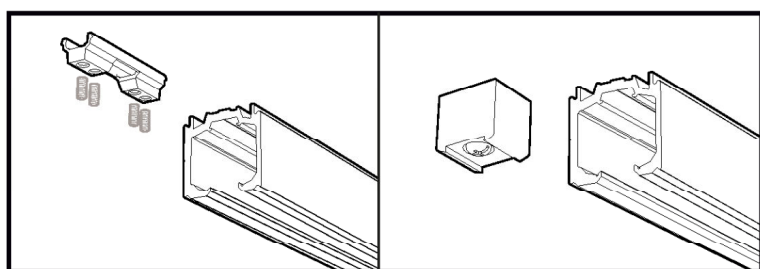
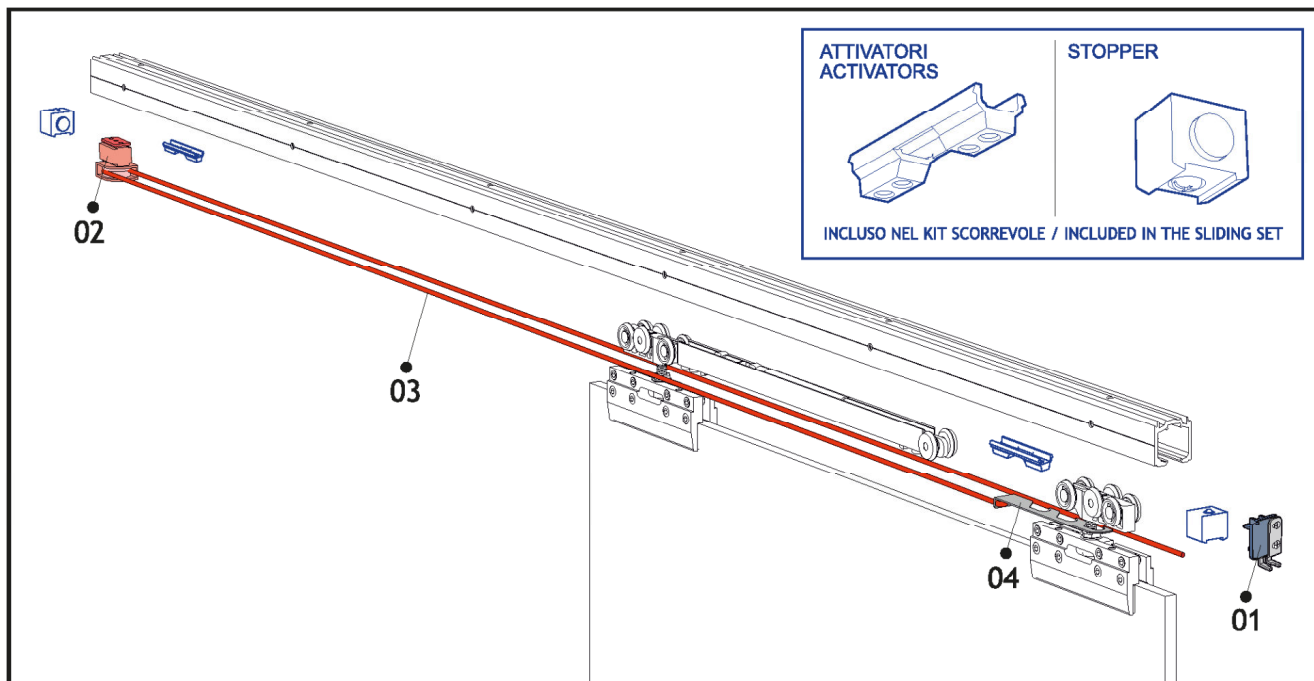
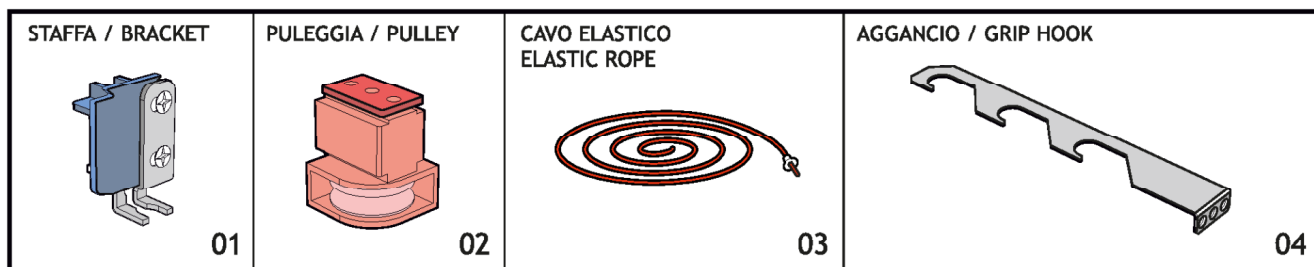

Dispositivo di chiusura automatica dell'anta per PANTA REI SOFT-CLOSE
Si abbina ai seguenti kit carrelli con soft close: PRS02-80, PRS02-80S, PRS02-110S, PRS03-80, PRS03-80S, PRS05-80, PRS05-80S, PRS05-110S, PRS07-80, PRS07-80S e PRS07-100S

ATTENZIONE: l'uso del dispositivo richiutore necessita differente posizionamento delle pinze e inferiore altezza della porta rispetto ai kit standard, da farsi in base alle indicazioni alle pagine successive

Self closing device for PANTA REI SOFT-CLOSE
It matches with the following soft close carriage sets: PRS02-80, PRS02-80S, PRS02-110S, PRS03-80, PRS03-80S, PRS05-80, PRS05-80S, PRS05-110S, PRS07-80, PRS07-80S e PRS07-100S

PLEASE NOTE: self-close device requires different clamp positioning and lower height of the door compared to standard sets. Please look at the following pages

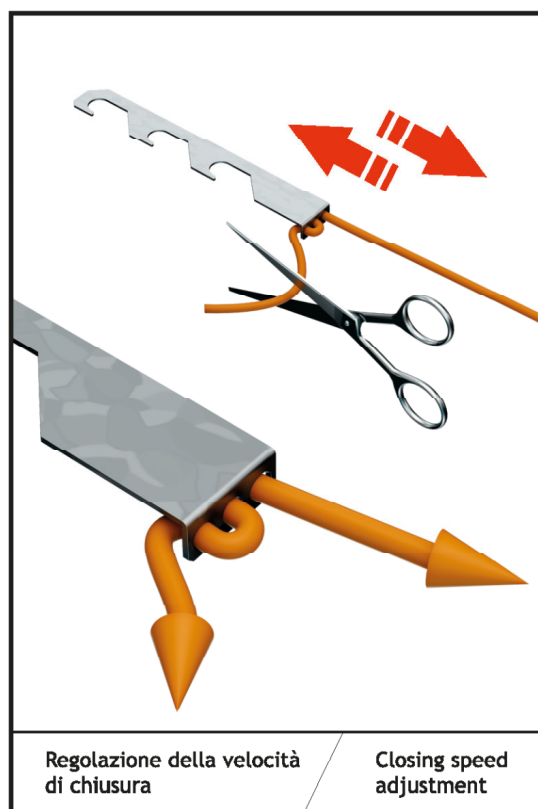

Regolazione della velocità di chiusura

Closing speed adjustment



PANTA REI AUTO

fissaggio a parete/wall fixing

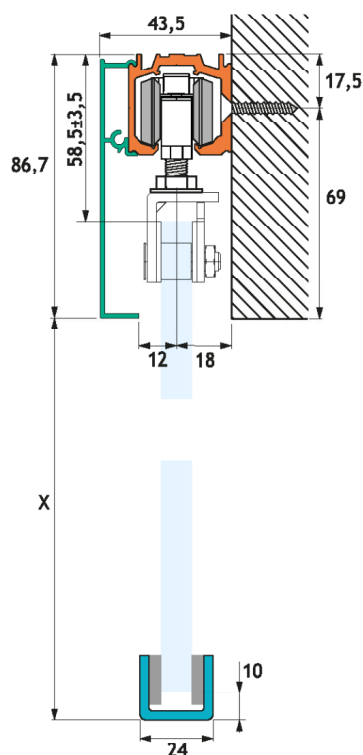
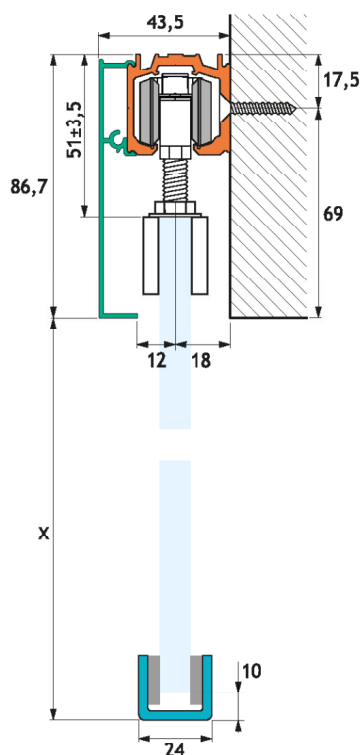

A) per kit PR02-60, PR02-110, PRS02-80, PRS02-80S, PRS02-110S
A) for PR02-60, PR02-110, PRS02-80, PRS02-80S, PRS02-110S sets

B) per kit PR03-60, PR03-80, PRS03-80, PRS03-80S
B) for PR03-60, PR03-80, PRS03-80, PRS03-80S, sets

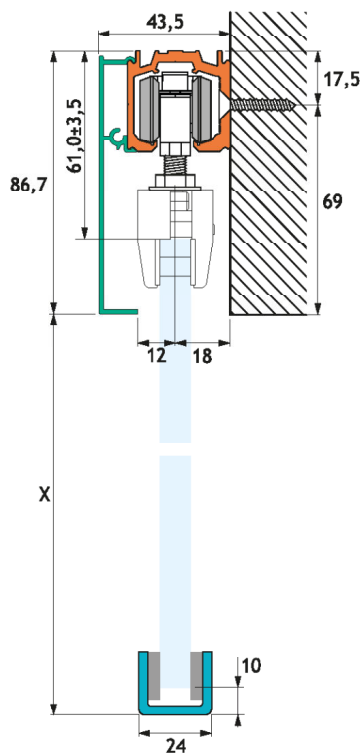
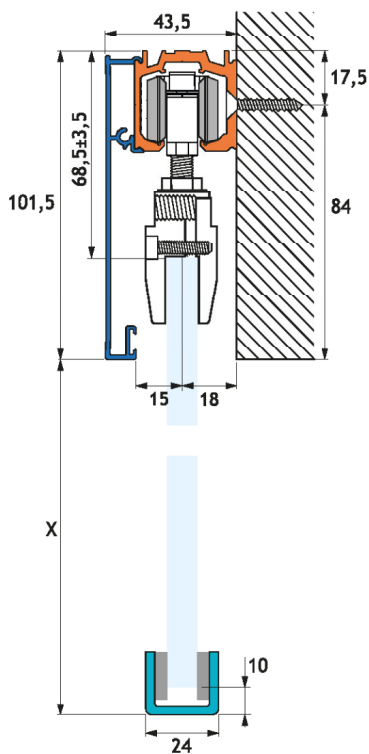

C) per kit PR05-60, PR05-110, PRS05-80, PRS05-80S, PRS05-110S
C) for PR05-60, PR05-110, PRS05-80, PRS05-80S, PRS05-110S sets

D) per kit PR07-60, PR07-100, PRS07-80, PRS07-80S, PRS07-100S
D) for PR07-60, PR07-100, PRS07-80, PRS07-80S, PRS07-100S sets

PANTA REI AUTO

fissaggio a soffitto/ceiling fixing

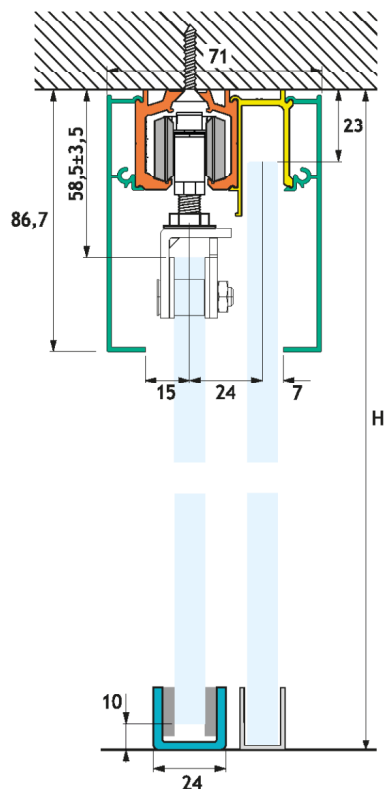
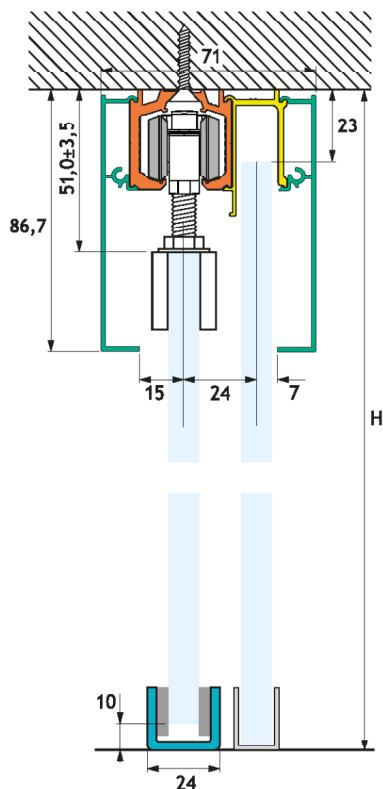

A) per kit PR02-60, PR02-110, PRS02-80, PRS02-80S, PRS02-110S
A) for PR02-60, PR02-110, PRS02-80, PRS02-80S, PRS02-110S sets

B) per kit PR03-60, PR03-80, PRS03-80, PRS03-80S
B) for PR03-60, PR03-80, PRS03-80, PRS03-80S sets

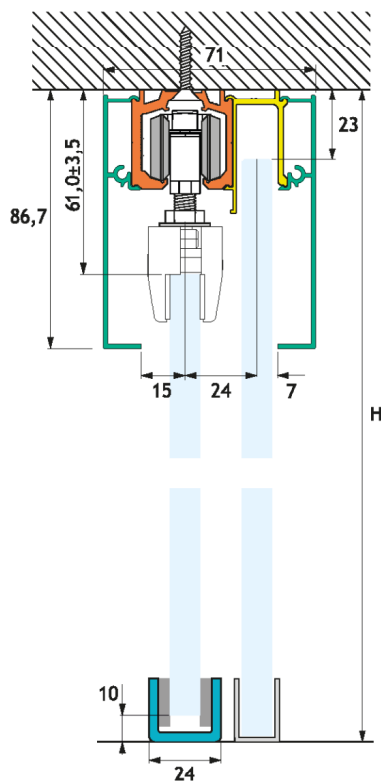
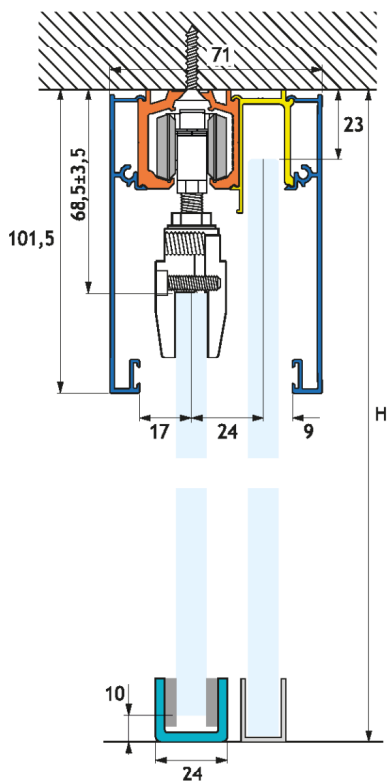

C) per kit PR05-60, PR05-110, PRS05-80, PRS05-80S, PRS05-110S
C) for PR05-60, PR05-110, PRS05-80, PRS05-80S, PRS05-110S sets

D) per kit PR07-60, PR07-100, PRS07-80, PRS07-80S, PRS07-100S
D) for PR07-60, PR07-100, PRS07-80, PRS07-80S, PRS07-100S sets

PANTA REI AUTO

fissaggio a soffitto/ceiling fixing

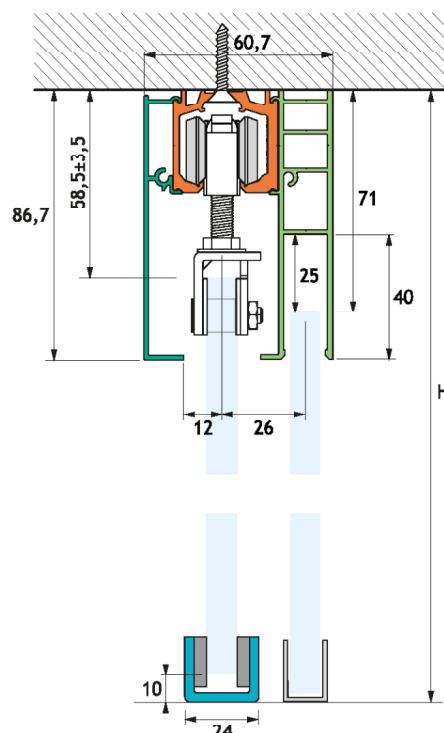
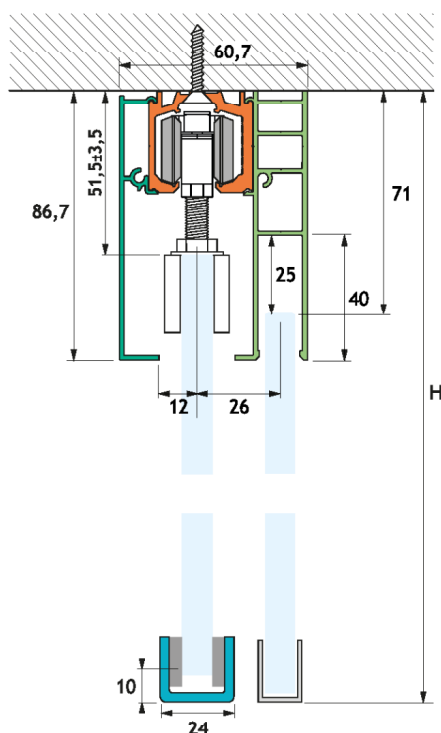

A) per tutti i kit PR02 e PRS02
A) for all PR02 and PRS02 sets

B) per tutti i kit PR03 e PRS03
B) for all PR03 and PRS03 sets

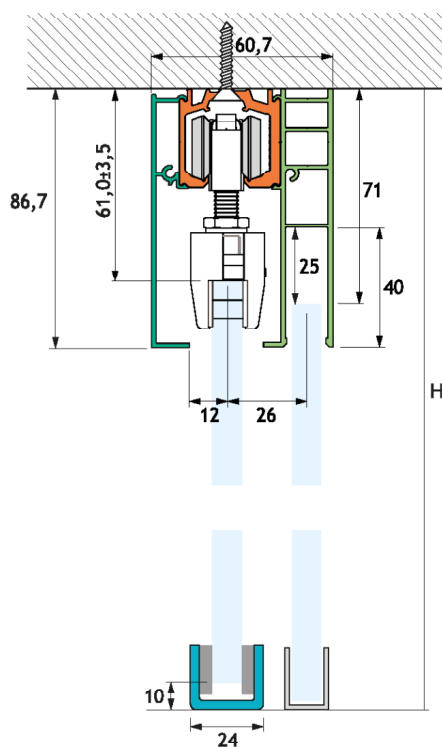

C) per tutti i kit PR07 e PRS07

C) for all PR07 and PRS07 sets

PANTA REI SOFT-CLOSE AUTO istruzioni di montaggio/fitting instructions

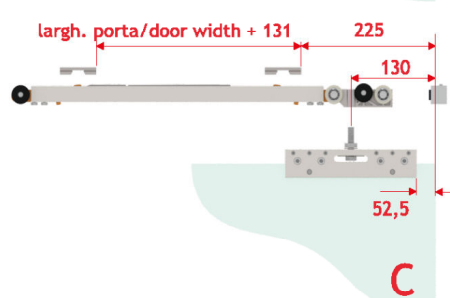
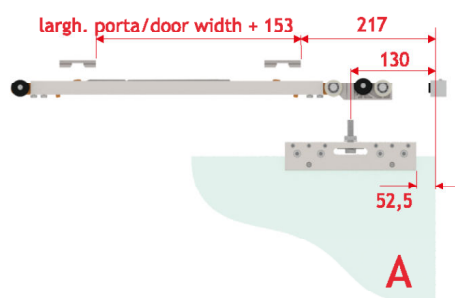
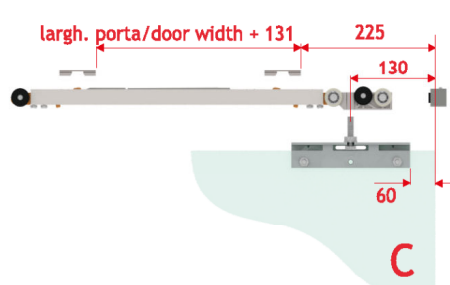
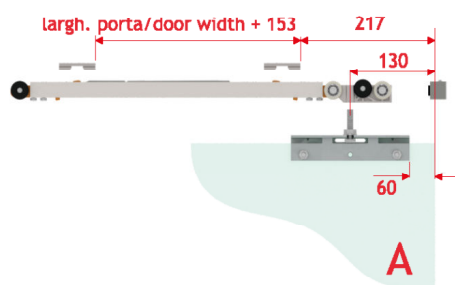
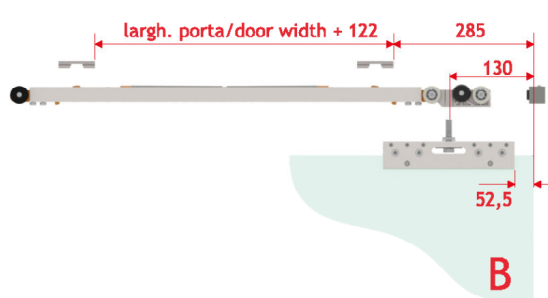
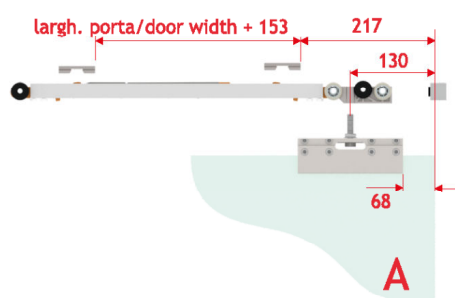
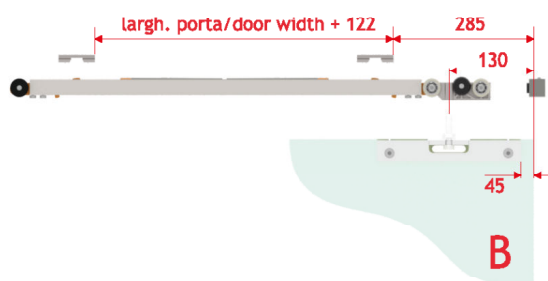
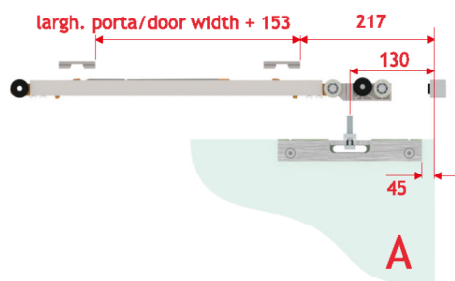

POSIZIONAMENTO DEGLI ATTIVATORI E DELLE PINZE

- A: tutti i kit 80 kg
- B: tutti i kit «S» 100/110 kg
- C: tutti i kit «S» 80 kg

ACTIVATORS AND CLAMPS POSITIONING

- A: all 80 kg sets
- B: all 100/110 kg «S» sets
- C: all 80 kg «S» sets